

Block cylinders

with metal wiper, single-/double-acting, pmax. 500 bar, piston with inner thread

200-3
Issue: 03/2023

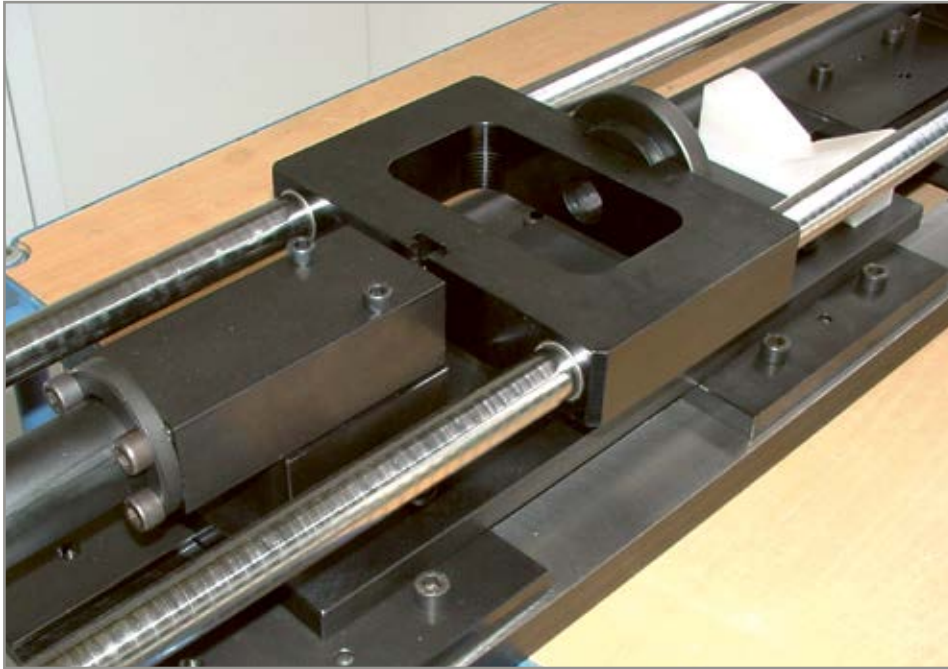

Webcode: 020003

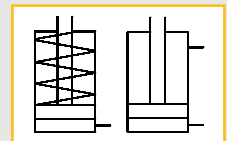

Application:

The picture shows a press-in fixture that mounts bearings on shafts. The block cylinder used has a stroke of 100 mm, in order to bridge the distances involved. Because of the wide variety of tools, the carriage can be ranged appropriately with the block cylinder. Supports of various lengths are mounted axially behind the block cylinder for this purpose. This results in only minimal bending forces being passed to the overall structure.

One special feature of the device lies in the pressure lowering function of the manual compressor. After the bearings have been preassembled they are secured mechanically under pre-tension. For this purpose the assembly pressure is released to approx. 60 bar by means of a manual ball valve and a downstream pressure limiting valve.

Flexible functional module:

- Plant construction
- Molt construction
- Mechanical engineering
- Fixture construction
- Toolmaking
- Moving
- Fixing
- Positioning
- Clamping
- Supporting
- single-acting without reset spring
- single-acting with reset spring
- double-acting

Wide range of strokes:

- various standard stroke lengths from 8 mm up to 200 mm
- special stroke lengths on request

Power range:

- from 2 kN with piston Ø 16 mm at 100 bar
- up to 392 kN with piston Ø 100 mm at 500 bar

Oil supply:

- ⊗ G1/4 / G1/2 threaded port
- ⊗ Manifold with O-ring bottom side, rod side or broadside

Sealing:

- ⊗ NBR, Operating temperature: -10° up to max. +80°C
- ⊗ FKM, Operating temperature: up to max. 150°C

Advantages:

- ⊗ Ideal for continuous operation with extremely low leakage
- ⊗ Space-saving installation
- ⊗ Four mounting options
- ⊗ Metal wiper as standard

Description:

Block cylinders are popular design elements in all areas where very powerful short strokes are required. Block cylinders have internal piston rod threads for secure screw-in contact bolts. (see page 4).

Their compact cubic shape facilitates attachment and guarantees high operating pressures. Various versions of hydraulic oil feed cover the whole range of applications.

The HYDROKOMP block cylinders offer technical advantages in the area of the seal at the piston-rod end. A double hydraulic seal is used here as standard, guaranteeing extremely low leakage in continuous operation.

All block cylinders are also equipped with a metal wiper ring, which prevents any metal shavings from penetrating into the flexible wiper ring.

We also design and manufacture customized variants!



HYDROKOMP®
Hydraulische Komponenten GmbH

- +49 6401 225999-0
- sales@hydrokomp.de
- Siemenstr. 16
35325 Mücke (Germany)
- www.hydrokomp.de

Technology that connects



A threaded port, bleeder and cross bores

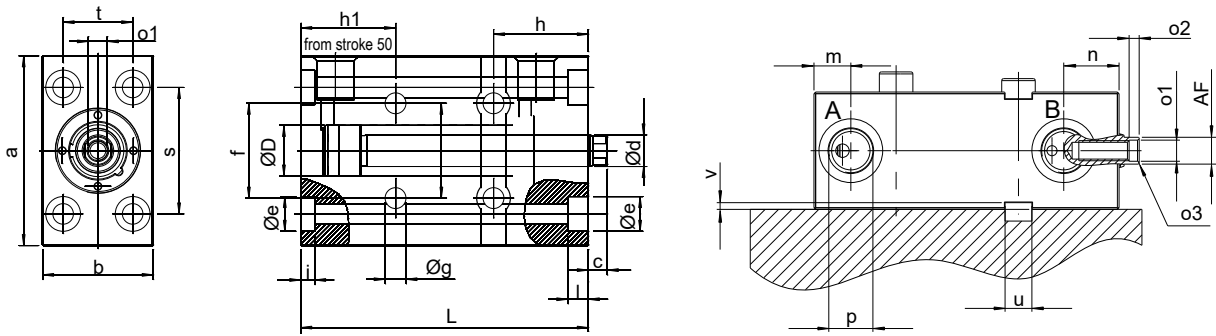

C manifold with O-ring, rod side

D manifold with O-ring, bottom side

E manifold with O-ring, broadside

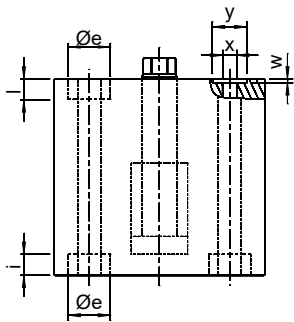

Design D, standard

Design D, centered bore⁽⁴⁾

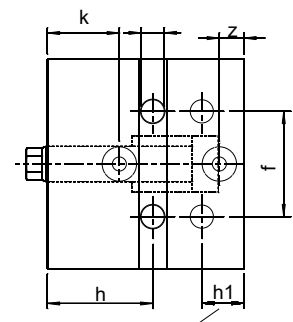
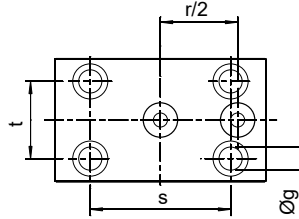
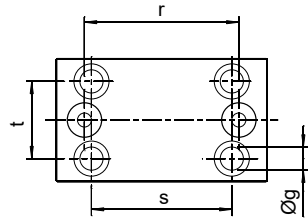

from stroke 50

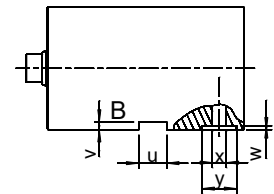
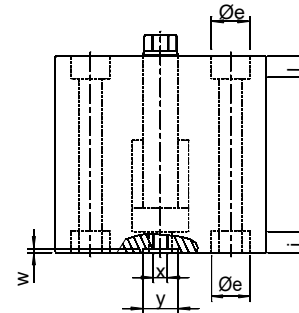
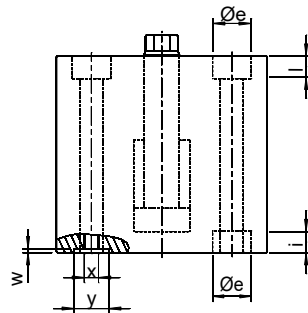
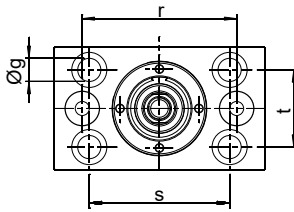

Mounting example

Mounting example

Mounting example

Mounting example

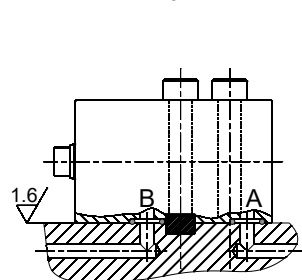
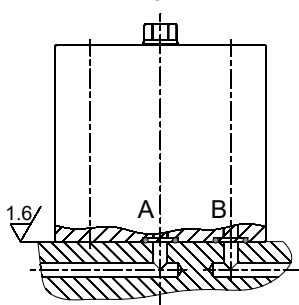
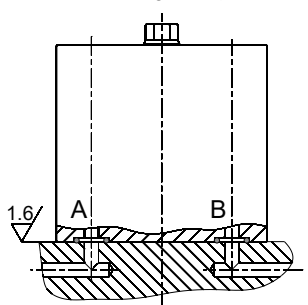
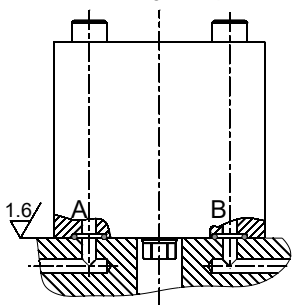

Order number key:

Scope of supply includes the O-rings.

Order numbers for spare parts see page 4.

Example: **BZY** - **032** - **100** - **AP001**

Piston Ø [mm]: 016, 020, 025, 032, 040, 050, 063, 080, 100

Stroke [mm]: (see table on page 3)

Design: **A, C, D, E** (see above)

Sealing: **NBR = P, FKM = V**

Functioning: double-acting = **001**, (optional centered bore at design D, double-acting = **011**)
 single-acting without spring reset = **002**
 single-acting with spring reset = **003**

⁽⁴⁾for Design **D**, centered bore, replace **001** with **011**.



D Piston Ø ⁽²⁾	[mm]	16	20	25	32	40	50	63	80	100	-
d Rod Ø	[mm]	10	12	16	20	25	32	40	50	63	-
Effective piston area	[cm ²]	2,0	3,1	4,9	8,0	12,5	19,6	31,1	50,3	78,4	-
Pressure force at 100 bar	[kN]	2,0	3,1	4,9	8,0	12,6	19,6	31,2	50,3	78,4	-
Tensile force at 100 bar	[kN]	1,2	2,0	2,9	4,9	7,7	11,6	18,6	30,6	47,4	-
a	[mm]	60	60	65	75	85	100	125	160	200	-
b	[mm]	35	35	45	55	63	75	95	120	150	-
c	[mm]	6	7	7	10	10	10	14	14	15	-
e Ø	[mm]	11	11	14	18	18	20	26	33	40	-
f	[mm]	30	40	50	55	63	76	95	120	158	-
g Ø	[mm]	6,5	6,5	8,5	10,5	10,5	13	17	21	25	-
h	[mm]	30	30	33	38	40	44	50	60	64	-
h1 (from stroke 50)	[mm]	24,5	24,5	26	27	27	30	41	47	54	-
i	[mm]	4,4	4,4	6,4	7,6	10,6	12,6	16,6	20,6	24,8	-
k	[mm]	20,5	20	21	25	27	29	32	39	40	-
l	[mm]	6,4	6,4	8,6	10,6	10,6	12,6	16,6	20,6	24,8	-
m	[mm]	11	11	11	11	11	13	17	21	25	-
n	[mm]	16,5	16,5	18	22	24	27	26	34	35	-
o1 = thread x depth	[mm]	M6x15	M8x16	M10x17	M12x18	M16x27	M20x32	M27x40	M30x40	M42x60	-
o2 = Ø x depth		Ø6,3x3	Ø8,5x3	Ø10,5x4	Ø12,5x4	Ø16,5x7	Ø21,0x8	Ø27,5x8	Ø30,5x8	Ø43,0x8	-
o3 = chamfer		0,5x30°	0,5x30°	0,5x30°	0,5x30°	0,5x30°	0,5x30°	0,5x30°	0,5x30°	0,5x30°	-
p		G1/4	G1/4	G1/4	G1/4	G1/4	G1/4	G1/2	G1/2	G1/2	-
r	[mm]	40	44	50	55	63	76	95	120	158	-
s	[mm]	40	40	50	55	63	76	95	120	158	-
AF		8	10	13	17	22	27	34	46	55	-
t	[mm]	22	22	30	35	40	45	65	80	108	-
u	[mm]	8	8	10	12	12	16	20	24	28	-
v	[mm]	2	2	2	3	3	5	5	7	7	-
w	[mm]	1,1	1,1	1,1	1,1	1,1	1,1	1,5	1,5	1,5	-
x Ø	[mm]	4	4	4	5	5	6	8	8	8	-
y Ø	[mm]	8,8	8,8	9,8	9,8	9,8	10,8	13,8	13,8	13,8	-
z	[mm]	7	7,5	7,5	10	10	13	16	21	25	-
single-acting with spring reset											
Stroke ⁽³⁾ ±1	[mm]	8	8	8	10	10	12	12	12	12	-
Housing length L ±1	[mm]	56	61	64	75	79	90	102	117	130	-
Order number	BZY...	-016-008-	-020-008-	-025-008-	-032-010-	-040-010-	-050-012-	-063-012-	-080-012-	-100-012-	...XY003
Stroke ⁽³⁾ ±1	[mm]	20	20	20	20	20	20	25	32	32	-
Housing length L ±1	[mm]	91	95	94	100	104	115	135	165	190	-
Order number	BZY...	-016-020-	-020-020-	-025-020-	-032-020-	-040-020-	-050-020-	-063-025-	-080-032-	-100-032-	...XY003
single-acting without spring reset											
Stroke ⁽³⁾ ±1	[mm]	16	16	20	-	-	-	-	-	-	-
Housing length L ±1	[mm]	56	61	64	-	-	-	-	-	-	-
Order number	BZY...	-016-016-	-020-016-	-025-020-	-	-	-	-	-	-	...XY002
Stroke ⁽³⁾ ±1	[mm]	32	32	-	25	25	25	30	32	40	-
Housing length L ±1	[mm]	73	77	-	75	79	90	102	117	130	-
Order number	BZY...	-016-032-	-020-032-	-	-032-025-	-040-025-	-050-025-	-063-030-	-080-032-	-100-040-	...XY002
Stroke ⁽³⁾ ±1	[mm]	50	50	50	50	50	50	63	80	-	-
Housing length L ±1	[mm]	91	95	94	100	104	115	135	165	-	-
Order number	BZY...	-016-050-	-020-050-	-025-050-	-032-050-	-040-050-	-050-050-	-063-063-	-080-080-	-	...XY002
Stroke ⁽³⁾ ±1	[mm]	-	-	100	100	100	100	100	100	100	-
Housing length L ±1	[mm]	-	-	144	150	154	165	172	185	190	-
Order number	BZY...	-	-	-025-100-	-032-100-	-040-100-	-050-100-	-063-100-	-080-100-	-100-100-	...XY002
Stroke ⁽³⁾ ±1	[mm]	-	-	-	160	160	160	160	160	160	-
Housing length L ±1	[mm]	-	-	-	213	217	228	236	249	254	-
Order number	BZY...	-	-	-	-032-160-	-040-160-	-050-160-	-063-160-	-080-160-	-100-160-	...XY002
Stroke ⁽³⁾ ±1	[mm]	-	-	-	-	-	-	200	200	200	-
Housing length L ±1	[mm]	-	-	-	-	-	-	276	289	294	-
Order number	BZY...	-	-	-	-	-	-	-063-200-	-080-200-	-100-200-	...XY002
double-acting											
Stroke ⁽³⁾ ±1	[mm]	16	16	20	-	-	-	-	-	-	-
Housing length L ±1	[mm]	56	61	64	-	-	-	-	-	-	-
Order number	BZY...	-016-016-	-020-016-	-025-020-	-	-	-	-	-	-	...XY001 ⁽⁴⁾
Stroke ⁽³⁾ ±1	[mm]	32	32	-	25	25	25	30	32	40	-
Housing length L ±1	[mm]	73	77	-	75	79	90	102	117	130	-
Order number	BZY...	-016-032-	-020-032-	-	-032-025-	-040-025-	-050-025-	-063-030-	-080-032-	-100-040-	...XY001 ⁽⁴⁾
Stroke ⁽³⁾ ±1	[mm]	50	50	50	50	50	50	63	80	-	-
Housing length L ±1	[mm]	91	95	94	100	104	115	135	165	-	-
Order number	BZY...	-016-050-	-020-050-	-025-050-	-032-050-	-040-050-	-050-050-	-063-063-	-080-080-	-	...XY001 ⁽⁴⁾
Stroke ⁽³⁾ ±1	[mm]	-	-	100	100	100	100	100	100	100	-
Housing length L ±1	[mm]	-	-	144	150	154	165	172	185	190	-
Order number	BZY...	-	-	-025-100-	-032-100-	-040-100-	-050-100-	-063-100-	-080-100-	-100-100-	...XY001 ⁽⁴⁾
Stroke ⁽³⁾ ±1	[mm]	-	-	-	160	160	160	160	160	160	-
Housing length L ±1	[mm]	-	-	-	213	217	228	236	249	254	-
Order number	BZY...	-	-	-	-032-160-	-040-160-	-050-160-	-063-160-	-080-160-	-100-160-	...XY001 ⁽⁴⁾
Stroke ⁽³⁾ ±1	[mm]	-	-	-	-	-	-	200	200	200	-
Housing length L ±1	[mm]	-	-	-	-	-	-	276	289	294	-
Order number	BZY...	-	-	-	-	-	-	-063-200-	-080-200-	-100-200-	...XY001 ⁽⁴⁾

Select the correct order number:

X replace by design (A, C, D oder E)

Y replace by sealing (P = NBR oder V = FKM)

⁽²⁾Other piston diameters and ⁽³⁾strokes are available on request.

⁽⁴⁾at design D, centered bore, replace 001 by 011.

Example: BZY-032-100-DP011

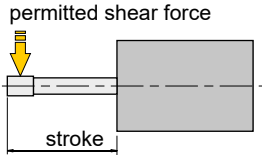

Permitted shear force with extracted piston rod

As far as possible avoid shear forces to guarantee sealing as well as longer lifetime of the piston and rod guide. For strokes up to 50 mm the shear force may not exceed 3% of the nominal cylinder force. For longer strokes the shear forces are to be reduced towards 0%. If transverse forces can not be avoided, guide housings need to be positioned correspondingly. Please contact us!

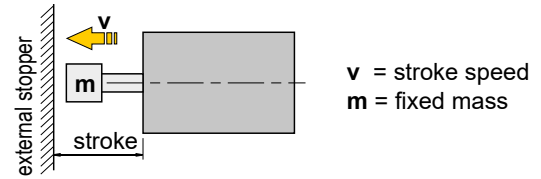

Permitted dynamic load with piston forward stroke

Block cylinders customarily do not have shock absorbing action. With the forward stroke the piston strikes the fixed body with undamped stroke speed against the sealing bush (cylinder stop position). The sealing bush could be overstressed by that. Operational safety would be impaired. In order to prevent that, the piston should always have an opponent external stopper.

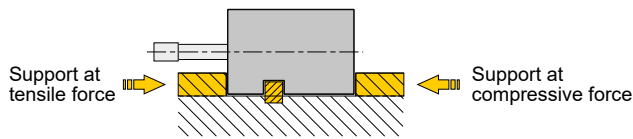

Supporting the block cylinder

If the block cylinder is to be fastened diagonally to the cylinder axis, we recommend to support the cylinder. When using as pressure cylinder, the support shall be at the bottom side, as tensile cylinder the support shall be at the rod side.

Alternatively the block cylinder can be supported by the transverse groove which is placed by default in the housing. In doing so, a fitting key is fastened on the mounting surface, absorbing the pressure or the force.

Design of a block cylinder:

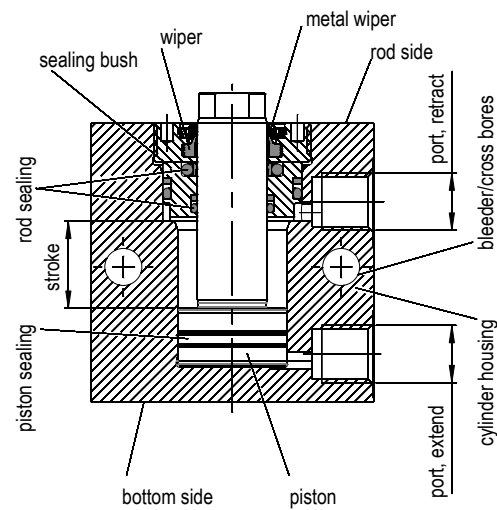

Contact bolts (accessories):

We offer contact bolts in various designs as accessories for the block cylinders. These are screwed into the inner thread of the piston rods. For dimensions and technical special features see datasheet 1000-1.

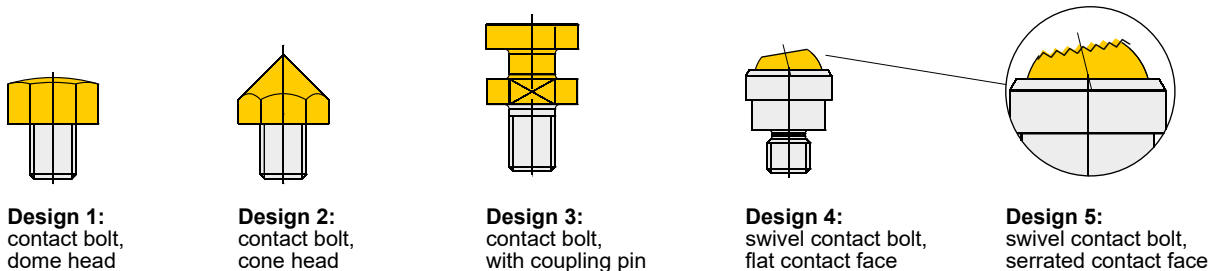

Piston Ø [mm]	Order no.	Order no.	Order no.	Order no.	Order no.
16	7006-049	7006-050	-	7006-051	7006-052
20	7008-071	7008-072	-	7008-073	7008-074
25	7010-012	7010-013	7010-014	7010-015	7010-016
32	7012-041	7012-042	7012-043	7012-044	7012-045
40	7016-003	7016-004	7016-005	7016-006	7016-007
50	7020-002	7020-003	7020-004	-	-
63	7027-001	7027-002	7027-003	-	-
80	7030-006	7030-007	7030-008	-	-
100	7042-002	7042-003	-	-	-

O-rings (spare parts):

Item:	Material: NBR		Material: FKM	
	Order no.	Order no.	Order no.	Order no.
O-ring 6x1,5	6006-001		6006-020	
O-ring 7x1,5	6010-002		6010-020	
O-ring 8x1,5	6011-002		6011-011	
O-ring 10x2	6010-003		6010-011	

Sealing kits (spare parts):

There are sealing kits for all block cylinders available. The order number for a sealing kit is derived from the suffix DS in combination with the order number of the block cylinder.

Example: DS-BZY-032-100-AP001